

# Vapor Compression Distillation



## DESIGN FEATURES

**COMPRESSORS** - Low-speed, direct drive compressors are offered on all units 1,500 GPH and above. High-speed compressors on smaller units use high-speed journal bearings for maximum life.

**EVAPORATOR** - The evaporator features a horizontal design using the Spray Film® process. It has a straight tube or U-tube configuration depending on size. Our process has eliminated the bottom hydraulic gasket, thus reducing maintenance.

**HOT OR AMBIENT DISTILLATE** - The stills can be designed to produce hot (85° C) distillate, ambient (15° warmer than feedwater) distillate or both. Output can range from 300 to 9,000 GPH.

**MATERIALS OF CONSTRUCTION** - Standard materials used are 316 stainless steel and product contact surfaces are 25 RA. Material certifications are provided for traceability and electropolish is available.

**SANITARY COMPONENTS**- Stills are manufactured using sanitary valves, instruments, pumps and piping. Heat exchangers are shell and tube design using double tube-sheets.

**AUTOMATION** - Stills are designed to operate automatically; stopping and starting based on level signals from WFI storage tank(s). A programmable logic controller (PLC) and human machine interface (HMI) are standard on all distillers.

**VARIABLE OUTPUT** - Our stills can be programmed for variable distillate capacity with turn-down to 60% of design flow using a variable frequency drive (VFD) on the compressor motor. Variable capacity allows the still to match the draw-down on the WFI tank(s) while reducing the number of starts and stops.

**DEAERATOR** - A 316L SST deaerator removes carbon dioxide, oxygen and other noncondensable gases from the feedwater or distillate.

**INSULATION** - The evaporator, deaerator, compressor, and ducting are insulated with low-chloride fiberglass and polished stainless steel lagging is available.



## BENEFITS

- + Spray-Film® vapor compression distillation units produce consistent, reliable, high-purity Water for Injection (WFI) for parenteral solutions.
- + Our patented Spray-Film® evaporator design provides improved wetting of the evaporator tubes and reduced scaling. This means less downtime for cleaning and higher operating efficiency.
- + The Spray Film® design includes a built-in, on-line cleaning system for removing scale and for repassivation. The cleaning system helps reduce maintenance costs and maintain high operating efficiency.
- + All major components are accessible from floor-level, with the compressor and pumps located at the edge of the skid for easy serviceability.
- + Our design offers reduced energy consumption and less stringent feed water requirements as compared to other distillation processes like multiple-effect systems.
- + Aqua-Chem's proven technology ensures superior TOC and endotoxin removal with minimal pretreatment.

## HOW AQUA-CHEM SPRAY-FILM® VAPOR COMPRESSION WORKS



Incoming feedwater is preheated by the outgoing blowdown and distillate. Feedwater and recirculation water are combined and sprayed over the outside of the evaporator tubes. Start-up/makeup steam is produced in the evaporator boiler. A portion of the spray is evaporated as pure steam and the remainder is collected in the sump to be further recirculated. A small amount of the collected water is discharged as blowdown to maintain desired concentration. Steam generated inside the evaporator is drawn through the demisters by the centrifugal compressor, and the temperature is increased in the compression process. The steam condenses inside the evaporator tubes and is collected as pure distillate. The distillate is pumped through the heat exchanger and into storage.

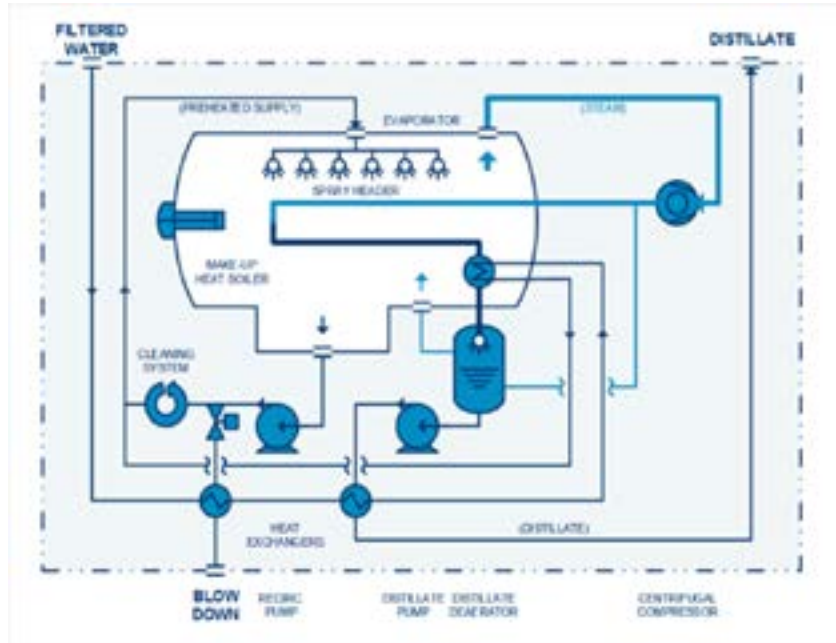

### SERVICE

We provide service and support for our equipment, even decades after installation. We continue to support units that were installed in the 1970s and 1980s. We maintain inventories of key components and consumables - and ensure that our service advisors are readily available for technical support via phone or e-mail.



Rev. 04102024